

TOOL FOR ROUNDING TENONING MACHINE

TRC5

Consisting of a cutter head Z=3+3 and of a circular blade with gleaners. It allows processing of tenons with length from 5 to 75 mm. For single tenoning. Left or right rotation.

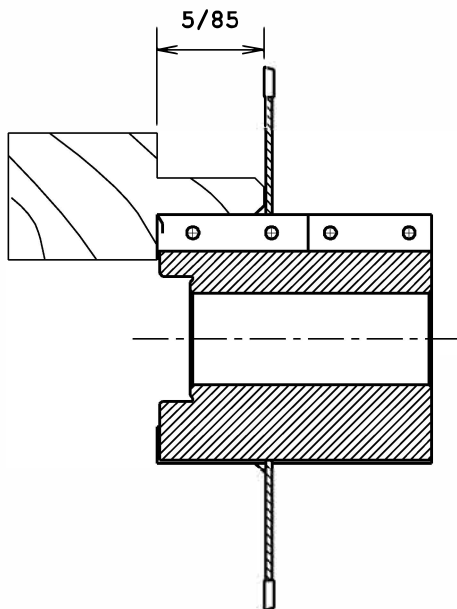
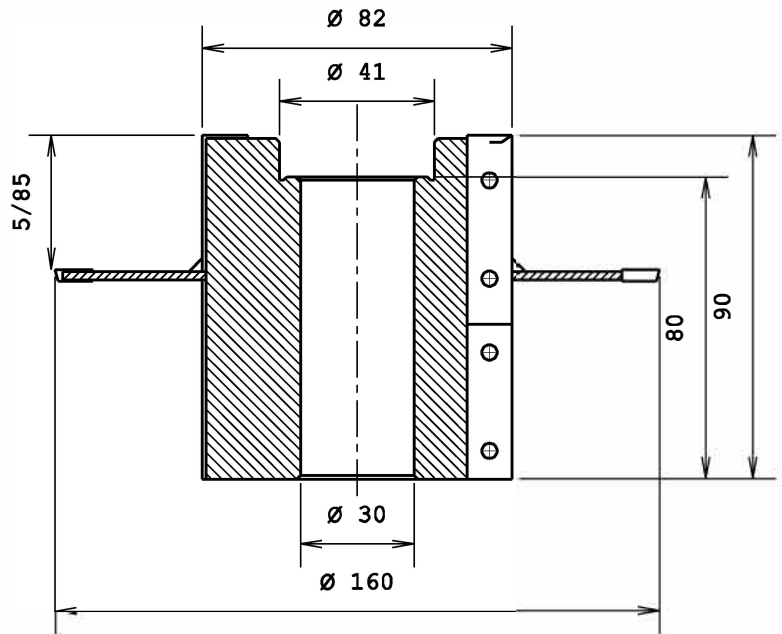
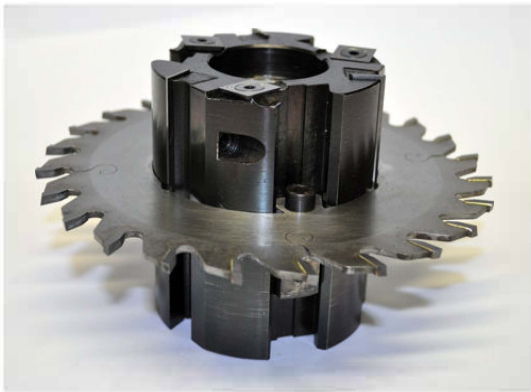

LCH/S

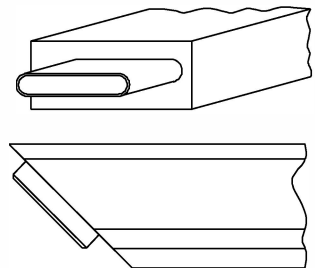
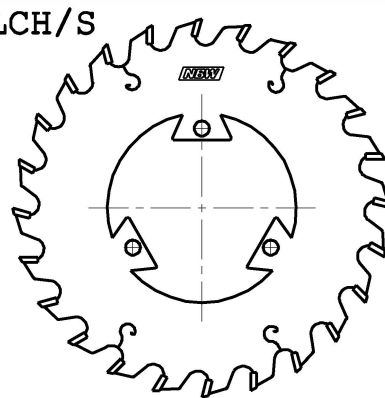

40x12x1.5

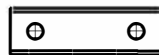

14x14x2



50x12x1.5

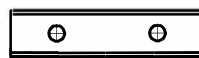

SM 45°



	D.	d.	h.	Z	Max turns	Cod.
Cutter head	82	30	90	3+3	9.000	TRC5
Hogger	160	80	3	24	9.000	