

CUTTER SET FOR TENONING MACHINE

FTE

Built with interchangeable blades carbide and gleaners adjustable for different tenon heights.

It allows processing of tenons with lengths from 10 to 50 mm. Right rotation

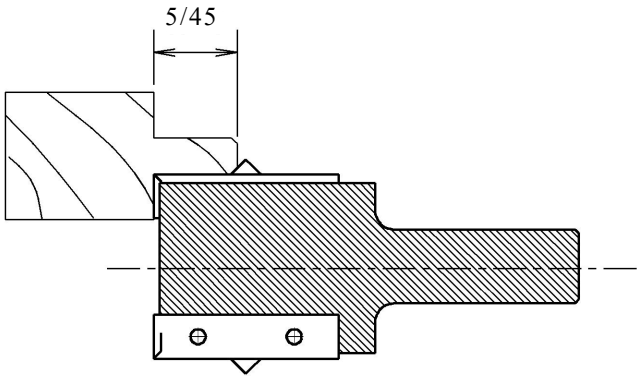
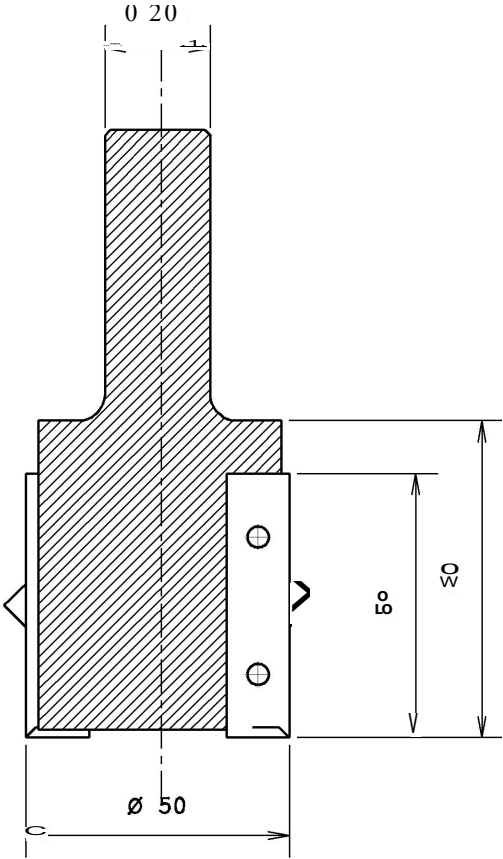

14x14x2

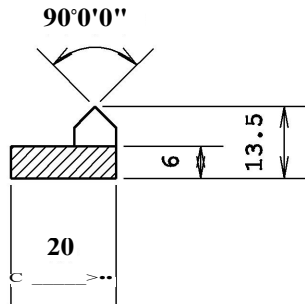

Optional $\frac{0}{50} \frac{0}{12} \frac{0}{1.5}$
50x12x1.5

50x12x1.5



	D.	d.	h.	Z	Max Turns	Code
Cutter-heads	50	20	60	2+2+4	18.000	FTE

Nuova brilwa s.r.l. Via Calvi,3 Carugo (Co) Tel-Fax 031761413